

The Battery Standard

(Installation)

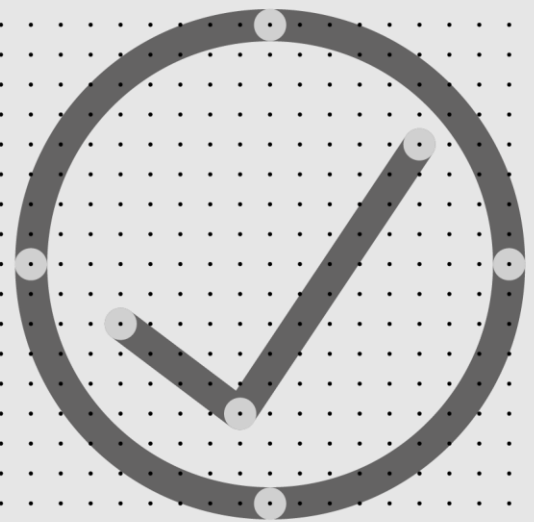

This Standard was prepared by the MCS Working Group 12: Battery Storage.

It is published by The MCS Service Company Ltd.

Whilst all reasonable care has been taken in the preparation of this document it is provided on an “as is” basis without any guarantee of completeness or accuracy. The MCS Service Company Ltd and The MCS Charitable Foundation (and any related parties) do not accept liability for any errors or omissions in the document nor for the use or application of the information, standards or requirements contained in the document by any third party.

The MCS Service Company Ltd welcomes comments of a technical or editorial nature and these should be sent to *meetings@mcscertified.com*

COPYRIGHT © The MCS Service Company Ltd 2021

This Standard is freely available for personal use. Commercial use by those not holding a valid licence to use the MCS mark is prohibited. In the context of this document commercial use is defined as:

- A manufacturer claiming that any of its products are certified in accordance with this document
- An installation or maintenance contractor claiming that its design, installation or maintenance services are either certified in accordance with, or compliant with, this document
- An organisation offering certification or verification services in accordance with this document

Any unauthorised reproduction use or transmission of all or part of this document without permission is strictly prohibited.

The MCS Service Company Ltd
Innovation Centre,
Sci-Tech Daresbury,
Keckwick Lane,
Cheshire WA4 4FS

www.mcscertified.com
hello@mcscertified.com
0333 103 8130

Issue: 1.0	COPYRIGHT © The MCS Service Company Ltd 2021	MIS 3012
Date: 22/11/2021		Page 2 of 40

ABOUT MCS

Giving you confidence in home-grown energy

With energy costs constantly rising and climate change affecting us all, low-carbon technology has a bigger and bigger role to play in the future of UK energy.

We're here to ensure it's a positive one.

Working with industry we define, maintain and improve quality – certifying products and installers so people can have confidence in the low-carbon technology they invest in. From solar and wind, to heat pumps, biomass and battery storage, we want to inspire a new generation of home-grown energy, fit for the needs of every UK home and community.

About

The Microgeneration Certification Scheme Service Company Ltd (MCSSCo Ltd) trades as MCS and is wholly owned by the non-profit MCS Charitable Foundation. Since 2007, MCS has become the recognised Standard for UK products and their installation in the small-scale renewables sector.

We create and maintain standards that allow for the certification of products, installers and their installations. Associated with these standards is the certification scheme, run on behalf of MCS by Certification Bodies who hold UKAS accreditation to ISO 17065.

MCS certifies low-carbon products and installations used to produce electricity and heat from renewable sources. It is a mark of quality. Membership of MCS demonstrates adherence to these recognised industry standards; highlighting quality, competency and compliance.

Vision

To see MCS certified products and installations in every UK home and community.

Mission

To give people confidence in low-carbon energy technology by defining, maintaining and improving quality.

Values

1. We are expert – ensuring quality through robust technical knowledge
2. We are inspiring – helping to reshape energy in UK homes and communities
3. We are collaborative – working with industry and government to create positive change
4. We are principled – operating in a way that's clear, open and fair
5. We are determined – supporting the UK's drive towards a clean energy future

Issue: 1.0	COPYRIGHT © The MCS Service Company Ltd 2021	MIS 3012
Date: 22/11/2021		Page 3 of 40

CHANGES TO STANDARDS

When MCS standards are revised, the issue number is also revised to indicate the nature of the changes. This can either be a whole new issue or an amendment to the current issue. Details will be posted on the website at www.mcscertified.com

Technical or other significant changes which affect the requirements for the approval or certification of the product or service will result in a new issue. Minor or administrative changes (e.g. corrections of spelling and typographical errors, changes to address and copyright details, the addition of notes for clarification etc.) may be made as amendments.

The issue number is given on the left of the decimal point, and the amendment number on the right. For example, issue 3.2 indicates that it is the third significant version of the document which has had two sets of minor amendments.

Users of this Standard should ensure that they are using the latest issue.

Issue No.	Amendment Details	Date
0.1	First Publication	20/01/2020
1.0	Align with 2 nd Edition (2020) of the IET Code of Practice and post-Brexit legislation. Clarify certain clauses relating to batteries.	22/11/2021

FOREWORD

This document contains references to other documents which may be either normative or informative. At the time of publication any editions of those documents, where indicated, were valid. However, as all documents are subject to revision, any users of this document should apply the most recent editions of those referenced documents.

This issue 1.0 is a significant update and replaces issue 0.1 which is withdrawn with immediate effect. Contractors looking to become certified against MIS 3012 can commence working to this standard from the date of its publication in preparation for certification assessments.

This Standard describes the MCS requirements for the assessment, approval and listing of contractors undertaking the supply, design installation, set to work, commissioning and handover of Electrical Energy (Battery) Storage systems by certification bodies. The listing and approval is based on evidence acceptable to the certification body:

- that the system or service meets the Standard
- that the contractor has staff, processes and systems in place to ensure that the system or service delivered meets the standard
- And on:
- periodic audits of the contractor including testing as appropriate
- compliance with the contract for the MCS listing and approval including agreement to rectify faults as appropriate

This Standard shall be used in conjunction with the scheme document MCS 001 and any other guidance and supplementary material available on the MCS website specifically referring to this Standard (MIS 3012).

NOTES:

This Microgeneration Installation Standard makes use of the terms 'must', 'shall' and 'should' when prescribing certain requirements and procedures. In the context of this document:

- *the term 'must' identifies a requirement by law at the time of publication;*
- *the term 'shall' prescribes a requirement or procedure that is intended to be complied with in full and without deviation;*
- *the term 'should' prescribes a requirement or procedure that is intended to be complied with unless reasonable justification can be given.*

Compliance with this Microgeneration Installation Standard does not in itself confer immunity from legal obligations.

Issue: 1.0	COPYRIGHT © The MCS Service Company Ltd 2021	MIS 3012
Date: 22/11/2021		Page 5 of 40

TABLE OF CONTENTS

- About MCS..... 3
- Foreword..... 5
- Table of contents..... 6
- 1 Purpose & Scope..... 7
- 2 Definitions..... 8
- 3 Requirements of the MCS Contractor..... 15
- 4 Pre-Sale information..... 15
- 5 Design & Installation Requirements..... 18
- 6 Commissioning & handover 26
- 7 Maintenance..... 28
- 8 Roles & Competency..... 28
- 9 Regional Offices..... 28
- 10 Publications, Reference and Further Reading 29
- Appendix A – Roles & Competency Requirements 30
- Appendix B – Performance Estimation method..... 32
- Appendix C – Commissioning Checklist for Domestic EESS..... 36

1 PURPOSE & SCOPE

This Standard specifies the requirements for MCS Contractors undertaking the supply, design, installation, set to work, commissioning and handover of electrical energy (battery) storage systems (EESS) for permanent buildings with a maximum power output of up to 50 kW in the use cases described in the table below. This Standard must be read in conjunction with the IET Code of Practice (CoP) for Electrical Energy Storage Systems.

The MCS Contractor shall be assessed under either of the following scope categories of EESS (based on the classifications given in section 2.2) and their certification noted accordingly:

- Limited-scope covering the installation of EESS classes 1, 2 and 3 inclusive.
- Full-scope covering installation of EESS classes 1, 2, 3 and 4 inclusive.

In order for the MCS Contractor to be certificated as Full Scope, a Class 4 system shall be assessed by the certification body.

Use Case	In or out of scope
EESS connected to a building's distribution board via its own dedicated DC to AC inverter and on the consumer's side of the supply meter (see Figure 3.1, Page 21, Figure 3.2, Page 22, and Figure 3.4, Page 23 of the IET CoP).	IN
EESS connected to the DC terminals of a DC to AC inverter which is simultaneously serving another form of generation (e.g. solar PV inverter) and on the consumer's side the supply meter (see Figure 3.5, Page 24, and 3.6, Page 24 of the IET CoP).	IN
As above in buildings with other forms of generation (e.g. wind turbine) (see Figure 3.4, Page 23 of the IET CoP).	IN
As above in buildings without other forms of generation (see Figure 3.1, Page 21 of the IET CoP).	IN
Primary batteries	OUT
Traction and vehicle starter batteries in vehicles	OUT
Secondary batteries in mobile and transportable units as described in Section 717 of BS 7671	OUT
EESS not connected behind a supply meter (otherwise known as "in-front of the meter" systems).	OUT
EESS in buildings without a permanent and normally live connection to the electricity distribution network ("off-grid")	OUT

Use Case	In or out of scope
Uninterruptible Power Supplies serving specific critical systems (e.g. IT systems, emergency systems etc)	OUT
Central power supplies and central battery units for emergency lighting systems	OUT
Primary batteries and secondary batteries in appliances; fire detection, alarm, indicating and annunciating equipment; security systems and equipment; and control and monitoring systems equipment (including BMS and HBES)	OUT
Secondary batteries in caravans, motorhomes and leisure accommodation vehicles as described in Section 721 of BS 7671	OUT

2 DEFINITIONS

2.1 GENERAL

Refer to MCS 001 for general definitions (not specific to EESS). For technical definitions please see the Glossary (Appendix A) of the IET Code of Practice for Electrical Energy Storage Systems.

Term	Definition
BMS	Battery management system
Battery	An arrangement of one or more electrically connected monoblocs for the purpose of storing and supplying DC power within an EESS.
Class	System classification (see Section 2.2).
Code of Practice (CoP)	IET Code of Practice for Electrical Energy Storage Systems 2 nd Edition (IET publication ISBN: 978-1-83953-041-8 Paperback, 978-1-83953-389-1 Electronic)
Design	The formulation of a written plan including a specific list of products and fixings to form a completed system for a defined microgeneration or storage technology. Including extensions and alterations to existing microgeneration or storage systems.
EESS Design	As Design defined in MCS 001 and, in addition, the process of selecting and matching components to components and systems to premises and application to maximise performance, safety and durability of the installation. Design of Class 4 EESS should be undertaken with particular care and requires specialist competency.

Term	Definition
Electrical Energy (Battery) Storage System (EESS)	A system which converts electrical energy into a form of energy which can be stored, the storing of that energy, and the subsequent reconversion, in a controllable manner, of that energy back into electrical energy.
Handover	The point in a contract where commissioning and certification of the system have been satisfactorily completed to the contract specification so enabling the installation to be formally explained and handed over to the client. Including all relevant documentation required by the relevant technology standard.
Installation	The activities associated with placement and fixing of an Electrical Energy Storage System.
Island mode isolator	Device that disconnects the live conductors of the grid supply when the system switches to island mode. Disconnection could be achieved by an isolation relay or contactor, or a manual changeover switch. See Section 9.4 of the IET Code of Practice for Electrical Energy Storage Systems.
Islanding arrangement	An arrangement of electrical equipment, including an island mode isolator and an N-E bond relay, and any associated control connections, to facilitate changeover to island mode.
Maintained circuit	Circuit which continues to receive power from an electrical energy storage system operating in island-mode.
Maintained load	Load which continues to receive power from an electrical energy storage system operating in island-mode.
Monobloc	An arrangement of one or more electrochemical secondary (rechargeable) cells. <i>Note: with some battery chemistries, monoblocs may contain internal monitoring, battery management and protection components.</i>
N-E bond relay	Device that establishes a neutral in parts of the installation disconnected from the grid supply in island mode by connecting it to a means of earthing. See section 9.4 of the IET Code of Practice for Electrical Energy Storage Systems.
PCE	Power conversion equipment, including inverters and combined inverter-chargers.
Self-consumption	The amount of electricity generated on-site (such as by Solar PV) which is subsequently used within the building and not exported to the distribution network.

2.2 SYSTEM CLASSIFICATION

Systems are classified based on the characteristics in Table 2.1. Examples of different classes of systems are shown in Figures 2.1 to 2.5 (note: there are other possible arrangements).

Table 2.1: Classification of EESS for the purposes of MIS 3012

System classification	Battery and PCE	Islanding arrangement (where appropriate)
Class 1	<p>Battery, BMS, PCE and islanding arrangement housed in same manufacturer-provided enclosure.</p> <p>PCE is G98 / G99 type tested as appropriate.</p> <p>No DC cabling outside manufacturer-provided enclosures.</p> <p>Single manufacturer or importer is responsible for performance, safety and warranty of all component products.</p>	<p>Islanding arrangement is housed in the same enclosure as the battery and PCE.</p> <p>Islanding arrangement is G98 / G99 type tested as appropriate</p> <p>Single manufacturer or importer is responsible for performance, safety and warranty of all component products.</p>
Class 2	<p>PCE is housed in a different enclosure to the storage battery and/or BMS. PCE is G98 / G99 type tested as appropriate.</p> <p>DC cabling may exist outside manufacturer-provided enclosures.</p> <p>Single manufacturer or importer is responsible for performance, safety and warranty of the component products.</p>	<p>Islanding arrangement may be housed in a separate enclosure to the PCE.</p> <p>PCE manufacturer or importer is responsible for the performance, safety and warranty of the islanding arrangement.</p> <p>Islanding arrangement is G98 / G99 type tested as appropriate</p>
Class 3	<p>PCE is housed in a different enclosure to the storage battery and/or BMS. PCE is G98 / G99 type tested as appropriate.</p> <p>DC cabling may exist outside manufacturer-provided enclosures.</p> <p>PCE manufacturer is responsible for performance, safety and warranty of the PCE. PCE is G98 / G99 type tested as appropriate.</p> <p>BMS manufacturer responsible for performance, safety and warranty of the battery and BMS products.</p> <p>The MCS Contractor is responsible for confirming compatibility between PCE and BMS.</p>	<p>Islanding arrangement may be housed in a separate enclosure to the PCE.</p> <p>PCE manufacturer responsible for the performance, safety and warranty of the islanding arrangement.</p> <p>Islanding arrangement is G98 / G99 type tested as appropriate</p>
Class 4 (full scope certified MCS Contractors only)	<p>Battery, BMS and PCE may all be from different manufacturers. System does not fall within the definitions of Class 1, Class 2 or Class 3 systems.</p> <p>The MCS Contractor is responsible for (or for arranging by others) system performance compliance, safety and warranty of the component products.</p>	<p>The MCS Contractor is responsible for performance, safety and warranty of the islanding arrangement and its integration with the system controls. Where not type-tested, installer is responsible for performing DNO-witnessed tests and obtaining DNO approvals.</p>

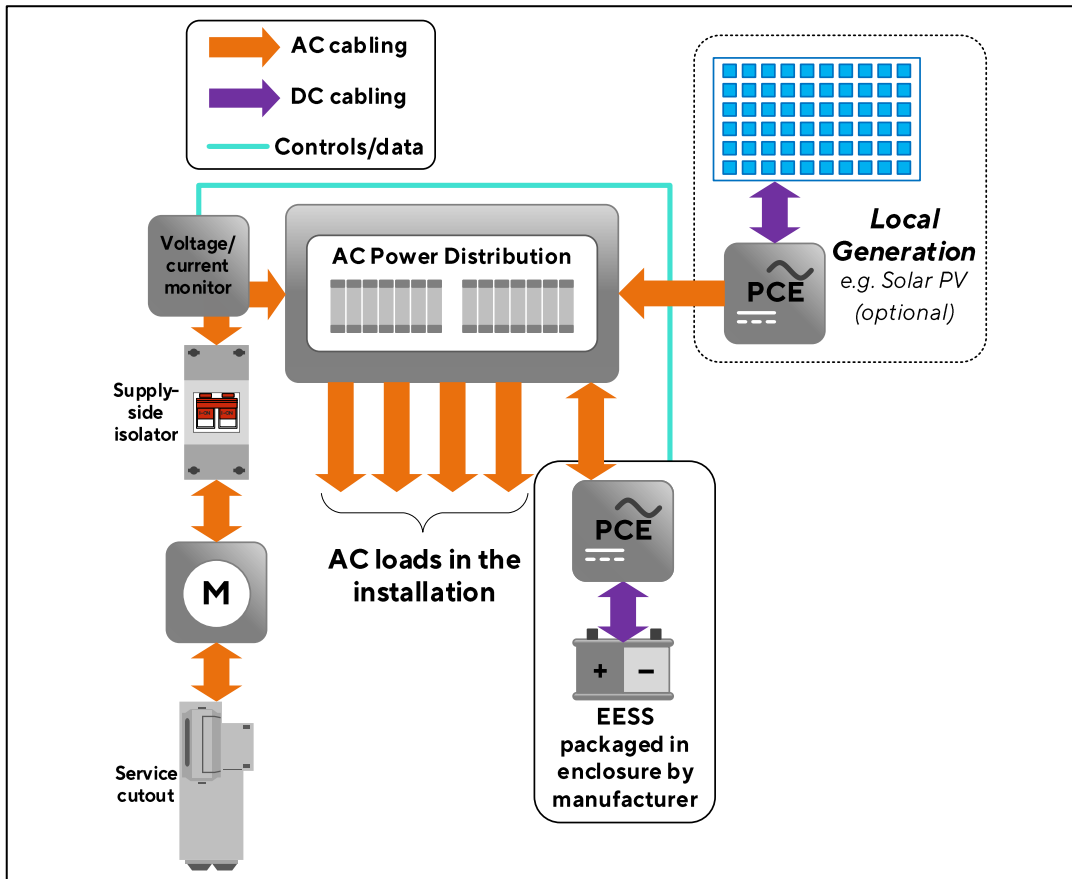

Figure 2.1 Example of Class 1 system without islanding arrangement

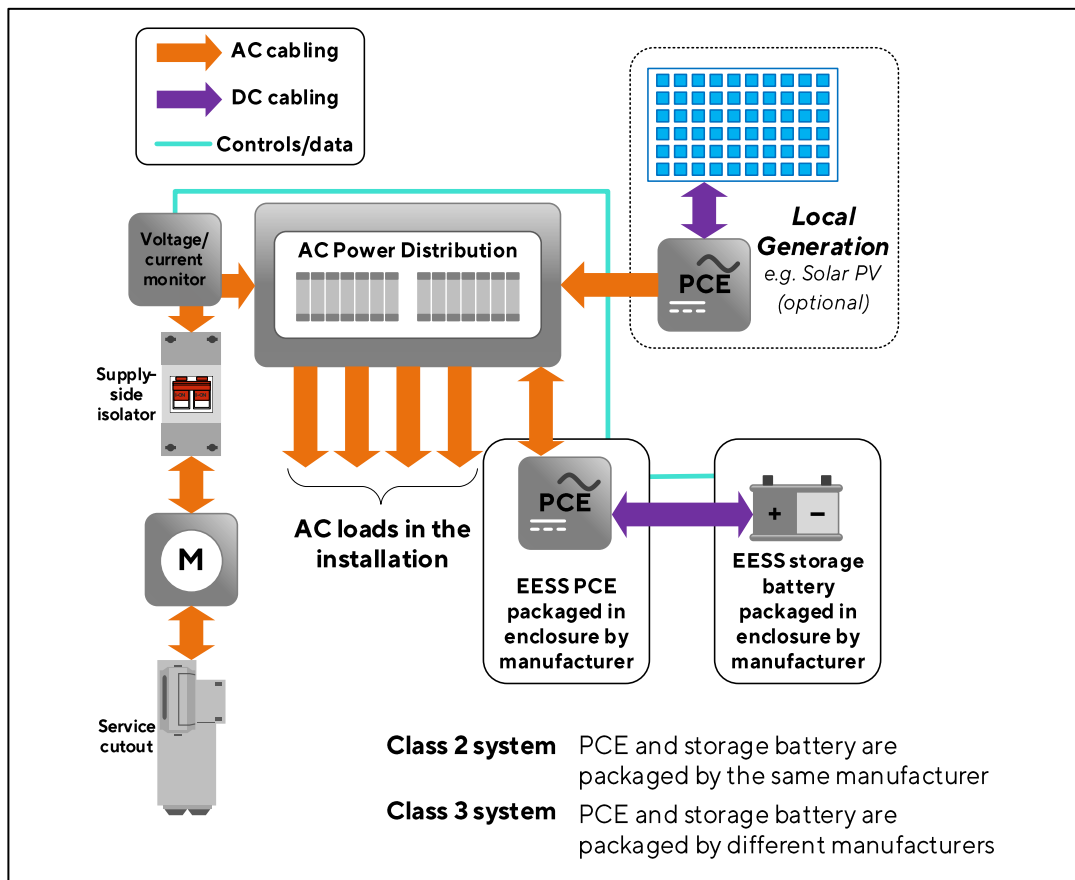

Figure 2.2 Example of Class 2 or Class 3 system without islanding arrangement

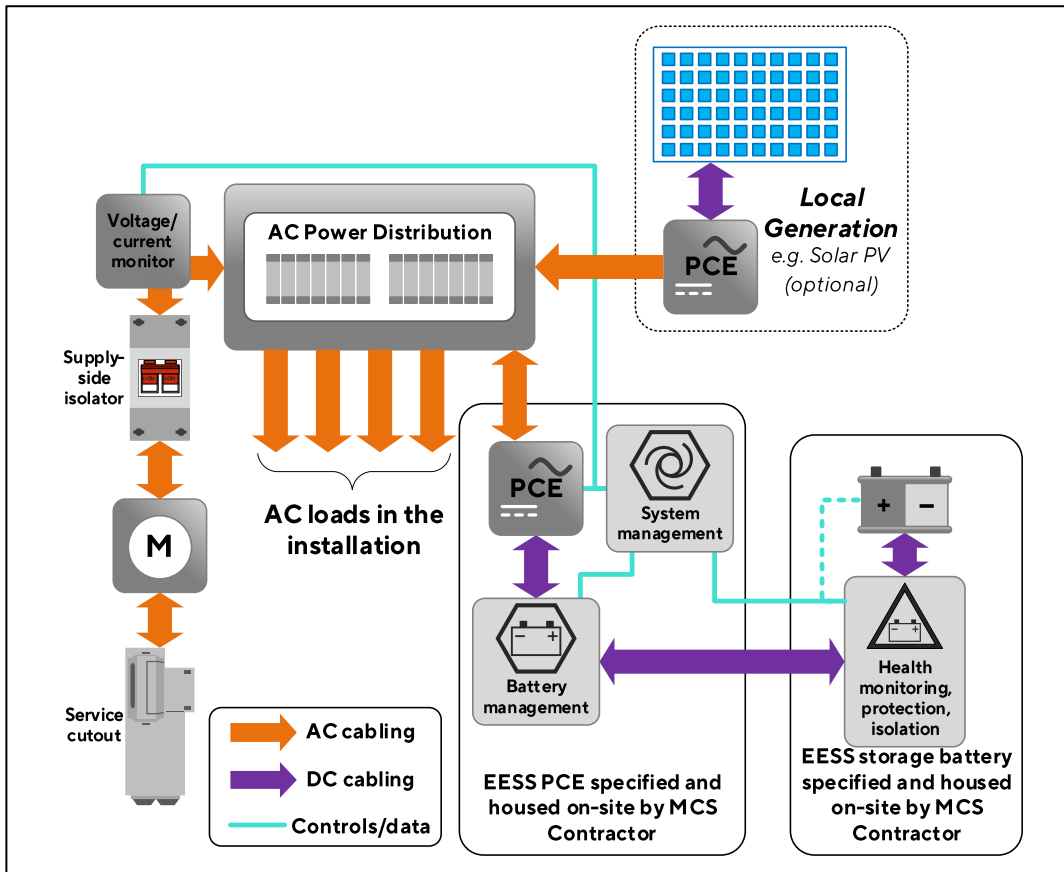

Figure 2.3 Example of Class 4 system without islanding arrangement

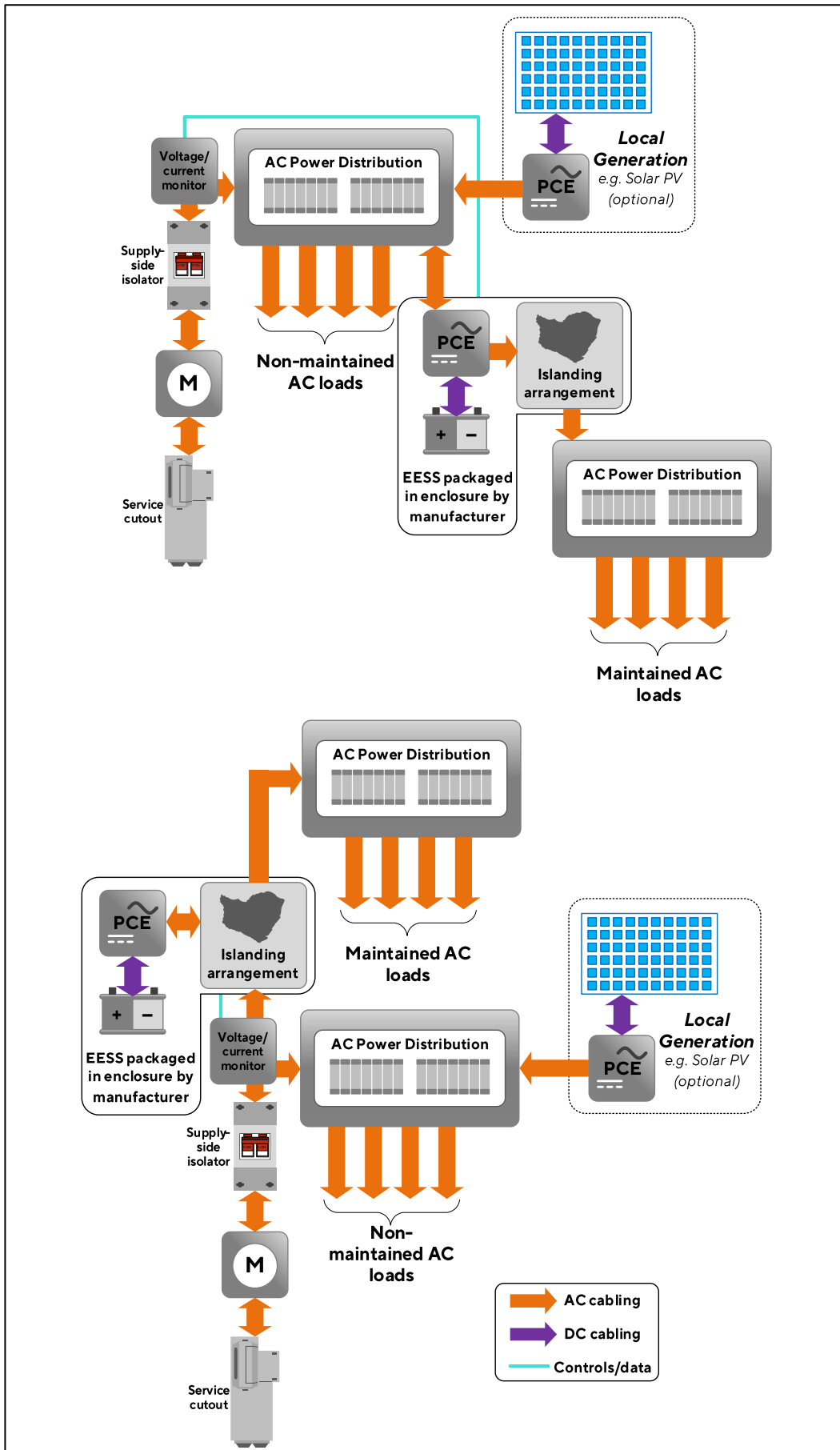

Figure 2.4 Examples of Class 1 systems with islanding arrangement

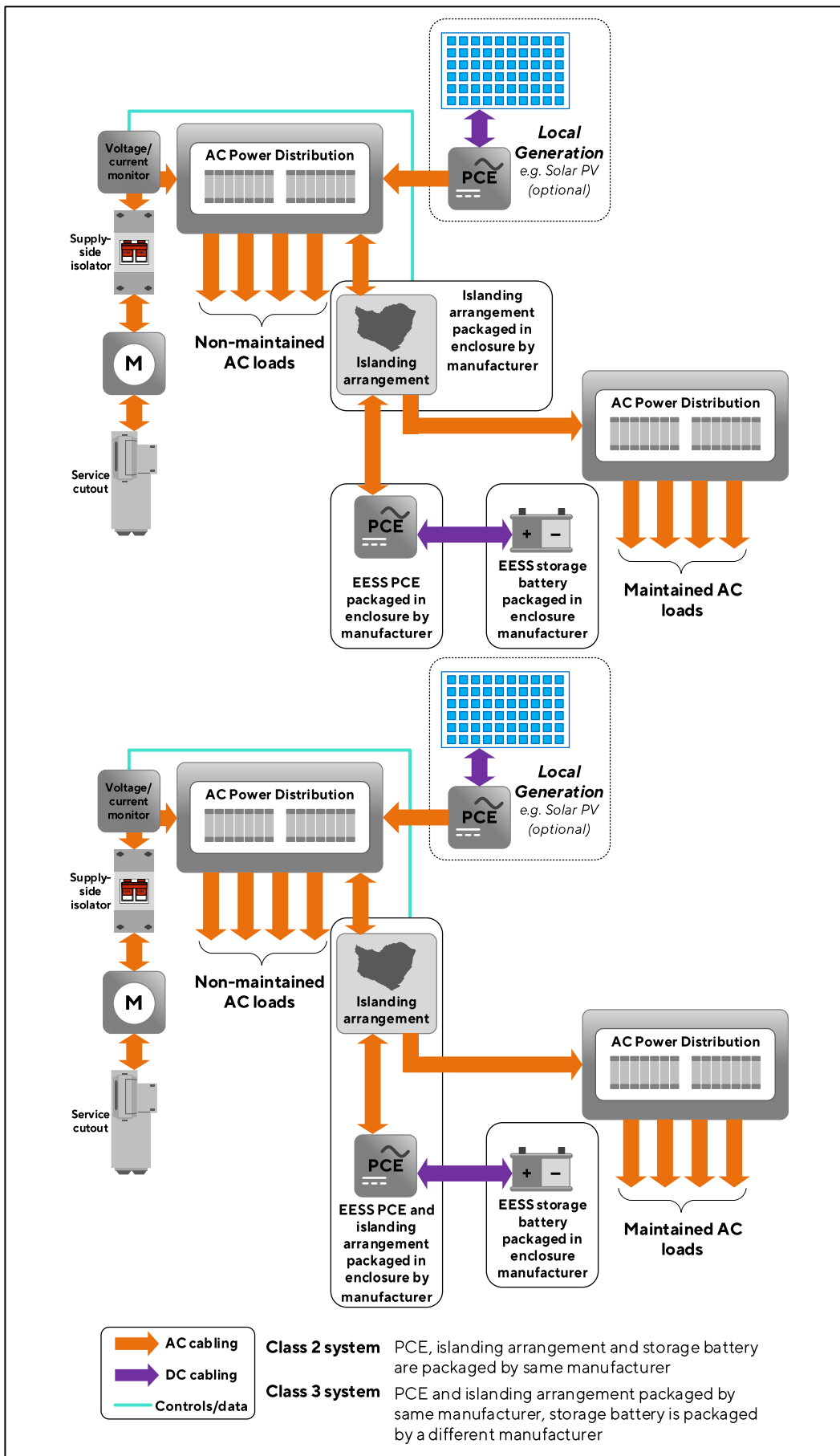

Figure 2.5 Examples of Class 2 and Class 3 systems with islanding arrangement

3 REQUIREMENTS OF THE MCS CONTRACTOR

3.1 CAPABILITY

- 3.1.1 MCS Contractors shall have the competency (see Section 8) and capacity to undertake the supply, design, installation, set to work, commissioning and handover of EESS.
- 3.1.2 Where MCS contractors do not engage in the design or supply of EESS, but work solely as a MCS Contractor for a client who has already commissioned a system design; then the MCS Contractor shall be competent to review and verify that the design would meet the design requirements set out in this Standard and this should be recorded.

3.2 ORGANISATION

- 3.2.1 MCS Contractors shall organise themselves using policies, procedures and systems which meet the minimum requirements in MCS001 to ensure every EESS installation meets this Standard.

Note: MCS001 includes requirements for Quality Management System, Consumer Care, Personnel, Continual Improvement, External Documents, Software Control, Customer Requirements, Contracts, Subcontracting, Purchasing, Test and Measurement Equipment, Product Handling, Training and Competence, all of which can affect the quality of installed systems.

4 PRE-SALE INFORMATION

4.1 PERFORMANCE ESTIMATION

- 4.1.1 An estimate of the annual energy performance of the system shall be made using the methodology detailed in Appendix B.
- 4.1.2 This estimate shall be communicated in the prescribed format to the client at or before the point that the contract is awarded and shall be accompanied by the following text:

“Important Note: The energy performance and benefits of EESS is impossible to predict with certainty due to the numerous functions a system can be programmed to perform. This estimate is based upon the standard MCS procedure and is given as guidance only. It should not be considered as a guarantee of performance.”

- 4.1.3 The results of the performance estimate shall be given in the format of Table 4.1.

Issue: 1.0	COPYRIGHT © The MCS Service Company Ltd 2021	MIS 3012
Date: 22/11/2021		Page 15 of 40

Table 4.1: Format of the annual energy performance estimate of an EESS

A. Solar PV Installation data	
Installed capacity of PV system – kWp (stc)	kWp
Orientation of the PV system – degrees from South	°
Inclination of system – degrees from horizontal	°
Postcode region	
B. Performance calculations	
kWh/kWp (Kk) from table	kWh/kWp
Shade Factor (SF)	
Estimated annual output (kWp x Kk x SF)	kWh
C. Estimated PV self-consumption – PV Only	
Assumed occupancy archetype	Home all day/ Home half day/ Out all day
Assumed annual domestic electricity consumption	kWh
Expected solar PV self-consumption (PV Only)	kWh
Grid electricity independence / Self-sufficiency (PV Only)	%
D. Estimated PV self-consumption – with EESS	
Assumed usable capacity of electrical energy storage device, which is used for self-consumption	kWh
Expected solar PV self-consumption (with EESS)	kWh
Grid electricity independence / Self-sufficiency (with EESS)	%
E. Additional benefits from PV and EESS	
EESS capacity not used for self-consumption	kWh
Total energy discharged per annum	kWh
Additional self-consumption from EV, heat pumps, diverters (only when present)	kWh

Notes:

Where the EESS is not installed in conjunction with Solar PV to increase the PV self-consumption then sections A, B, C, D in the above table can be omitted.

Kk values for solar PV are obtained from the tables in MIS 3002 or Irradiance Datasets downloadable from the MCS website.

4.1.4 Additional estimates may be provided using an alternative methodology, including proprietary software packages, but:

- 4.1.4.1 such estimates shall clearly describe and justify the approach taken and factors used
- 4.1.4.2 they shall not be given greater prominence than the standard MCS estimate
- 4.1.4.3 they shall be accompanied by warning text stating that it should be treated with caution if it is significantly better than the result given by the standard method.

4.2 MINIMUM TECHNICAL INFORMATION

4.2.1 As a minimum, the following technical information shall be communicated in writing to the client before the point that the contract is awarded:

- a) The result of the performance estimate calculated in accordance with Section 4.1.
- b) The classification of the system (see Section 2.2).
- c) The battery type and any special precautions that should be taken such as ventilation and fire safety.
- d) The physical characteristics of the system (size and weight).
- e) The proposed location of the system.
- f) Whether AC or DC coupled and if using an existing in-situ inverter.
- g) Maximum power output in kilowatts (kW).
- h) Maximum continuous current output in amperes (A).
- i) The useable storage capacity in kilowatt-hours (kWh) accounting for the maximum allowable depth of discharge.
Note: it would be helpful for consumers if the useable storage capacity could be expressed in terms of the time that particular devices could be run. For example, a 100 W Television with 100 W of lighting could run for X hours.
- j) Round-trip efficiency (%) and energy loss (kWh) if charged from grid electricity.
- k) Current cost of additional or replacement batteries, monoblocs or cells.
- l) If capable (or not) of running in Island mode (during loss of grid power) and limitations in terms of maximum load in kW.
- m) Warranties applying to the system and its storage capacity (degradation, number of cycles, energy throughput etc.)
- n) How the EESS indicates its current usable capacity or state of health (thus indicating if it is ending its life or the storage capacity is below the warranted capacity).
- o) For Class 3 and Class 4 systems, the warranties provided for each discrete component.
- p) End of life, recycling, arrangements in accordance with the Waste Electrical and Electronic Equipment Regulations 2013 as amended and the Batteries and Accumulators (Placing on the Market) Regulations 2008 as amended.
- q) Where the EESS is to be remotely controlled by third parties, the terms of that arrangement including the terms applying should the consumer wish to terminate the arrangement and assume full control of their system. Penalties for early termination shall be clearly stated.

Issue: 1.0	COPYRIGHT © The MCS Service Company	MIS 3012
Date: 22/11/2021	Ltd 2021	Page 17 of 40

- r) If the EESS can be controlled to respond to time of use electricity tariffs and, if so, how. It shall be highlighted whether this is a manual process (manually setting charge and discharge times) or can be automated (such that charge and discharge times change automatically when tariffs change).

Note: it is the intention of MCS to review MIS 3012 such that, when the technology and communication protocols become commercially available, requirements will be introduced stipulating that EESS certifiable under MCS shall be able to communicate directly and locally with smart meters in real time and respond automatically where programmed to do so. Systems not able to operate this way may cease to be compliant.

Furthermore, systems that seek to keep consumers captive within a particular software platform, limiting consumers' choice of how their EESS can be used, may also be restricted or otherwise made non-compliant through the introduction of relevant requirements.

5 DESIGN & INSTALLATION REQUIREMENTS

5.1 LEGISLATION

- 5.1.1 All applicable legislation must be met in full.

Note: the legislation which applies may be different in England, Wales, Scotland and Northern Ireland.

- 5.1.2 MCS Contractors shall ensure, and be able to demonstrate, that they are aware of all current applicable legislation.
- 5.1.3 MCS Contractors shall make their customers aware of all permissions and approvals required for the installation.
- 5.1.4 The MCS Contractor shall assess the building using a competent professional experienced in EESS to ensure that it is suitable for the installation and, by undertaking the proposed works, the building's compliance with the Building Regulations (in particular those relating to energy efficiency and electrical safety) is not compromised.
- 5.1.5 Suitable and sufficient risk assessments shall be conducted before any work on site commences.
- 5.1.6 A Construction Phase Plan in accordance with the Construction (Design and Management) Regulations 2015 shall be drawn up before work on site commences.
- 5.1.7 Where work is undertaken that is notifiable under the Building Regulations it shall be made clear to the customer who shall be responsible for this notification.
- 5.1.8 The MCS Contractor shall ensure that notification under the Building Regulations has been completed prior to handing over the installation.

Issue: 1.0	COPYRIGHT © The MCS Service Company Ltd 2021	MIS 3012
Date: 22/11/2021		Page 18 of 40

Note: Self-certification, in lieu of building control approval, is only permitted where installation and commissioning is undertaken by a person or organisation deemed competent and registered with a Competent Persons Scheme (CPS) approved by the Department for Levelling Up, Housing & Communities (DLUHC) for the scope of work being undertaken. Further details can be found at <http://www.competentperson.co.uk>.

- 5.1.9 The MCS Contractor must ensure the installation is compliant with the Electrical Safety, Quality and Continuity Regulations 2002 and, in accordance with Regulation 22(2)(c), must follow the technical requirements and procedures:
- a) In Engineering Recommendation (EREC) G98 for installations up to and including 16 A per phase
 - b) In EREC G99 for installations exceeding 16 A per phase.
 - c) In EREC G100 where the export of power is to be limited
- 5.1.10 Notification to the distribution network operator in accordance with the procedures set out in EREC G98 or EREC G99 (full or fast-track process as appropriate) shall be undertaken by the MCS Contractor.

Note: the 16 A per phase threshold is the total aggregated AC output of all generators. For example, a 3 kW solar PV system and a 3 kW electrical energy (battery) storage system are connected in parallel to the same single-phase AC supply, gives a combined maximum theoretical output greater than 16 A. In this case EREC G99 applies.

5.2 STANDARDS AND INDUSTRY PRACTICES

- 5.2.1 EESS shall be designed and installed in accordance with the latest edition of the IET Code of Practice for Electrical Energy Storage Systems – hereafter referred to as the Code of Practice – and paragraphs 5.5 to 6.1.3 below.
- 5.2.2 For a particular installation, should a conflict arise between specific requirements, then the latest version of BS 7671 shall take precedence over paragraphs 5.5 to 6.1.3 below, which in turn shall take precedence over the Code of Practice.
- 5.2.3 All references in both this standard, and the Code of Practice, to Designated Standards for demonstration of conformity to relevant legislation shall be read as a version of that standard in the current Lists of Designated Standards available on the UK Government website, or any designated replacement standard should that standard have been removed from the list.

Note: at the time of publishing this Standard, the Lists of Designated Standards are available at the following Web address: <https://www.gov.uk/guidance/designated-standards>

- 5.2.4 All references in both this standard, and the Code of Practice, to other national or international standards shall be read as the latest version of that national or international standard, or any superseding standard should the standard be withdrawn.

Issue: 1.0	COPYRIGHT © The MCS Service Company	MIS 3012
Date: 22/11/2021	Ltd 2021	Page 19 of 40

5.2.5 References in the Code of Practice to ERECs G98 and G99 shall be read as the latest version of those ERECS.

5.3 MANUFACTURER'S INSTRUCTIONS

5.3.1 All equipment should be installed in accordance with its manufacturer's instructions.

5.3.2 Where the manufacturer's instructions conflict with the requirements of this standard then the requirements of this standard take precedence unless it can be demonstrated that the manufacturer's instructions will result in an improved system or the manufacturer's warranty would be made void.

5.4 EQUIPMENT CERTIFICATION AND LISTING

5.4.1 All installed equipment should be suitable for its application and have a manufacturer's declaration of conformity for the appropriate standard.

5.4.2 Generating plants (inverters) must be fully type-tested to the latest standards required by the Energy Networks Association recommendations. Refer to Clause 10 "Publications for Reference and Further Reading" for details of the changes to the Engineering Network Codes.

5.4.3 All batteries and equipment should comply with relevant British or Harmonised standards:

5.4.3.1 Components and assemblies should comply with relevant standards accepted by relevant UK legislation. Where applicable, the requirements of EREC G98 and G99 apply.

5.4.3.2 MCS Contractors shall ensure that EESS meets the requirements of the Electromagnetic Compatibility Regulations 2016. MCS Contractors shall ensure that all selected components of Class 3 and Class 4 systems are compatible.

5.5 DESIGN AND INSTALLATION

General

5.5.1 Means of protection against electric shock, overcurrent and overload current according to BS 7671 shall be provided for all modes of operation.

5.5.2 Any earth electrodes provided for or utilised by the EESS shall meet the requirements of BS 7671 and BS 7430.

System Control

5.5.3 Controls shall be designed and configured to avoid jitter, and nuisance-switching between operating modes.

Issue: 1.0	COPYRIGHT © The MCS Service Company Ltd 2021	MIS 3012
Date: 22/11/2021		Page 20 of 40

5.5.4 The storage battery shall cease delivering power before it exceeds its maximum recommended depth of discharge.

Island mode operation

5.5.5 When the system switches to island-mode:

- a) All line conductors and neutral of the island mode part of the electrical installation, shall be isolated from the grid supply using an island mode isolator.
- b) The protective earth of the grid supply shall not be isolated.
- c) The neutral of the island mode part of the installation shall be connected, at one point only, through an N-E bond relay , to a means of earthing having a maximum earth electrode resistance Z_{EE} selected in accordance with Figure 9.10 of the Code of Practice.
- d) Any required neutral-earth bond shall be made immediately after the island mode isolator opens.

5.5.6 When the system switches out of island mode any neutral-earth bond shall be broken immediately before the island mode isolator opens.

5.5.7 When operating in island-mode, means of protection against electric shock shall not rely on the distributor’s means of earthing (for example, the earth terminal or conductor provided by the distributor for TN-S and TN-C-S supplies). Where necessary, an earth electrode shall be provided.

5.5.8 The preferred earthing arrangement for island-mode operation shall be TN-S.

5.5.9 Where it is not practicable for a TN-S earthing arrangement to be achieved in island-mode operation, TT shall be used.

5.5.10 The use of IT systems in island-mode shall be limited to systems that are maintained by competent persons, and due assessment has been made of the connected loads. IT systems shall be designed to disconnect after first fault, unless the installation is under the constant supervision of a responsible person.

Note 1: Certain common appliances and items of electrical equipment are not compatible with IT systems.

Note 2: BS 7671 strongly recommends against IT systems with distributed neutrals.

5.5.11 The designer and installer shall verify that protection against electric shock is provided for all maintained circuits in accordance with BS 7671 and the Code of Practice.

5.5.12 The circuit connecting the EESS generator to the installation must be designed so that it is protected against electric shock, fault current and overload current in accordance with BS 7671.

Issue: 1.0	COPYRIGHT © The MCS Service Company Ltd 2021	MIS 3012
Date: 22/11/2021		Page 21 of 40

- 5.5.13 In circuits that are energised in island mode, where an RCD is used to achieve the disconnection time for automatic disconnection required by BS 7671, the residual current rating must be selected taking into account the resistance of the island-mode earth electrode, in accordance with the Code of Practice.
- 5.5.14 Where automatic disconnection using a protective device is not feasible, the output of all power converting equipment supplying the installation in island-mode shall comply with regulation 419.2 of BS 7671.
- 5.5.15 The designer shall, as far as practicable, ensure selectivity between protective devices of final circuits for maintained loads, and the devices or equipment used to achieve the requirements in paragraphs 5.5.12, 5.5.13 and 5.5.14. Where selectivity is not practicable, so that a single fault may cause interruption of power to all maintained loads, this shall be clearly highlighted in the Contract, and documented in the user instructions.
- 5.5.16 The island mode isolator and N-E bond relay shall be rated in accordance with the Code of Practice.

Storage Batteries

- 5.5.17 Storage batteries shall not be located where they are at risk of accidental damage for which their enclosure is not designed.
- 5.5.18 All storage batteries intended for use in dwellings shall comprise, or be housed in, a suitable enclosure meeting at least IP2X as defined in BS EN 60529, with top surfaces at least IP4X as defined in BS EN 60529. Battery terminals and electrical connections shall be protected to at least IP3X, or shall be inaccessible without the use of a tool. Where BS 7671 requires a higher ingress protection rating for the location, BS 7671 requirements shall take precedence. Access to monoblocs or cells shall be by tool only.
- 5.5.19 Regardless of operating voltage, batteries, and any wiring system and means of connection, shall not be considered SELV or PELV unless the manufacturer of all power converting equipment connected to the storage battery confirms that the requirements of SELV or PELV are met.
- 5.5.20 In Class 2, Class 3 and Class 4 systems, all electrical equipment for use in DC circuits must be rated for DC use. Conductors terminated by the MCS Contractor shall be identified in accordance with BS 7671.

Current transformers

- 5.5.21 Current transformers and wiring connecting them to shunt devices shall be considered to operate at low voltage (Band II) unless the manufacturer of the current transformer confirms it meets the requirements for SELV or PELV.

Issue: 1.0	COPYRIGHT © The MCS Service Company Ltd 2021	MIS 3012
Date: 22/11/2021		Page 22 of 40

5.5.22 Current transformers shall be housed and connected so that accidental removal of the current transformer does not affect export limitation or load curtailment arrangements in the installation.

Additional Requirements for Class 4 EESS

*Note: the clauses in this section (5.5.17 to 5.5.31 inclusive) do **not** apply to Class 1, Class 2 and Class 3 EESS.*

5.5.23 All storage battery and charging equipment installations shall be designed in accordance with BS 7671, BS EN IEC 62485-1 and BS EN IEC 62485-2 and, where lithium battery chemistries are used, BS EN IEC 52485-5, taking into account specific recommendations of the storage battery manufacturer for accommodation.

5.5.24 All AC electrical equipment shall be capable of safe operation in line with the most onerous conditions of utilisation voltage presented by BS EN 50160, BS 7671 and EREC G98 or G99 as appropriate.

5.5.25 Conductors and terminals in pre-manufactured assemblies shall be identified in accordance with BS EN IEC 60445.

5.5.26 Charge management equipment shall comply with the storage battery manufacturer's recommendations for charge management and monitoring.

5.5.27 Charging shall cease when the storage battery voltages, currents or temperatures when charging move outside safe parameters published by the storage battery manufacturer.

5.5.28 Charging equipment shall identify the health of the storage battery. When the storage battery health is in question, the storage battery shall neither be charged or discharged, and a fault indication raised to the user, and indicated on an accessible control or indication panel.

5.5.29 PCE used for charging storage batteries shall match the electrical properties of the storage battery as specified by the battery manufacturer.

5.5.30 PCE shall not be used in a manner that exceeds its electrical ratings.

5.5.31 Except for commercial and industrial applications that are designed for fully-staffed operation, adjustment and regulation of charge voltages and currents to the profiles recommended by the storage battery manufacturer shall be automatic and require no user intervention.

5.5.32 All battery enclosures and/or battery rooms shall comply with BS 7671 and BS EN IEC 62485-1 and BS EN IEC 62485-2, and, where lithium battery chemistries are used, BS EN IEC 62485-5, and shall contain provisions appropriate to the battery chemistries involved.

Issue: 1.0	COPYRIGHT © The MCS Service Company Ltd 2021	MIS 3012
Date: 22/11/2021		Page 23 of 40

- 5.5.33 When covers are removed from storage battery enclosures, or within battery rooms, terminals of battery components shall be protected to at least IP2X as defined in BS EN 60529, and/or have some form of plastic cover to prevent inadvertent short-circuits during inspection, testing, fault-finding and maintenance operations. Storage batteries shall be arranged so that, during access to the enclosure or battery room, it is not possible to inadvertently make simultaneous contact with a potential difference exceeding 120_V.
- 5.5.34 All storage batteries shall incorporate a means of overcurrent protection within, or as close as possible to, the output terminals, of the storage battery or its enclosure.
- 5.5.35 All storage batteries shall incorporate a means of isolation as close as possible to the output terminals of the storage battery enclosure.
- 5.5.36 Where the system incorporates export limitation or load curtailment, the system shall monitor for faults or removal of load and export monitoring current transformers. The system shall be arranged so that a faulty or disconnected current transformer does not lead to the export limit or the installation maximum demand being exceeded.

5.6 METERING & COMMUNICATION

Metering

- 5.6.1 Where energy is taken from the grid to be stored in the EESS and later returned to the grid or installation, that energy shall not affect the veracity of any meters recording energy generated, imported or exported and where those meters are used for billing or payment.

Note: An example would include the meter recording total generation of a solar PV system where the recorded energy is used for payment of financial incentives such as the Feed-in Tariff. Any error in that reading could cause a claim for payment to be inaccurate and fraudulent. For the avoidance of doubt this clause allows for the correct recording by the supply meter of the energy taken from the grid to be stored in the EESS.

Data Communication & Security

- 5.6.2 The data privacy and security of the site's home area network shall be maintained. Where the installation comprises of any internet connected devices:
- The device's network access credentials (username & passwords) shall be updated in consultation with the customer
 - Relevant components in the EESS shall comply with the technical specification ETSI Technical Specification 103 645 Cyber Security for Consumer Internet of Things.
- 5.6.3 Installations requiring local area network, home area network, and/or internet access in commercial and industrial premises shall comply with the client organisation's information technology and information security policies and procedures.

Issue: 1.0	COPYRIGHT © The MCS Service Company	MIS 3012
Date: 22/11/2021	Ltd 2021	Page 24 of 40

5.7 SAFETY AND COMPONENT LOCATION

General

- 5.7.1 All components shall be located so that escape routes from the premises are not impeded.
- 5.7.2 Storage batteries shall be located so that a fire in the battery does not compromise protected escape routes.
- 5.7.3 All storage battery enclosures, battery rooms, and locations in which battery enclosures are installed, shall have adequate ventilation to prevent overheating during charging operations, and, where necessitated by the battery chemistry, to prevent explosive concentrations of evolved gasses.
- 5.7.4 Except where the entire battery enclosure is intended to be returned to a manufacturer's designated repair facility, maintenance instructions for the battery shall be provided, which include details of arc flash working procedures and the required personal protective equipment. If the information is not available from the battery manufacturer, the MCS Contractor shall provide the information after completing and documenting an arc flash risk assessment in accordance with Appendix E of the Code of Practice.
- 5.7.5 Storage batteries shall be located and housed in an appropriate location for the arc flash incident energy of all batteries in the location. Where the battery manufacturer does not provide specific information for location of an enclosed battery, or where monoblocs or multiple batteries are connected on-site, the MCS Contractor shall complete and document an arc flash risk assessment in accordance with Appendix E of the Code of Practice, to determine an appropriate location for the battery or batteries.

Weight and accessibility

- 5.7.6 All components shall be mounted on surfaces that are structurally sound and can support the weight of all components mounted on them. Both point loading and weight distribution shall be taken into consideration. If there is any doubt whatsoever then a qualified structural engineer shall be consulted.
- 5.7.7 The means of wall mounting for converters, batteries and similar components shall comply with the wall-mounting requirements of BS EN 62109-1.
- 5.7.8 Where reinforcement of walls and floors is required, the requirements and responsibility for these works shall be identified as part of the Contract.
- 5.7.9 Storage batteries and other components of the system shall be located so that any installation, commissioning and maintenance operations can be carried out safely, considering the weight of components and any lifting and manual handling operations required.

Issue: 1.0	COPYRIGHT © The MCS Service Company Ltd 2021	MIS 3012
Date: 22/11/2021		Page 25 of 40

5.7.10 All components shall be located so that there is adequate workspace, and access for installation, commissioning and maintenance operations. Space should also be available for temporary task lighting for such operations, where permanent lighting is not present in the location.

5.8 SITE SPECIFIC ISSUES

5.8.1 Storage battery chemistry shall be selected taking into account any fire suppression systems that are currently installed, or planned to be installed, in the location in which the storage battery is to be installed.

5.8.2 Storage batteries shall not be subject to submersion during foreseeable flood and inundation conditions.

Note: Certain battery chemistries must not come into contact with water.

5.8.3 Where power converting equipment and/or storage batteries are located in a rarely visited part of any premises, appropriate fire detection equipment should be installed in that location, complying with BS 5839-1 or BS 5839-6 as appropriate. Any fire detection equipment should be integrated with any existing fire detection and alarm system in the premises, and the means of integration shall comply with BS 5839-1 or BS 5839-6 as appropriate.

6 COMMISSIONING & HANDOVER

6.1 COMMISSIONING

6.1.1 The EESS shall be commissioned according to a documented procedure to ensure that the system is safe, has been installed in accordance with the requirements of this standard and the manufacturers' requirements, and is operating correctly in accordance with the system design.

Note: An example of a suitable commissioning checklist, based on the checklists in Section 12 of the Code of Practice, is shown in Appendix C. This should be provided in addition to any certification and schedules required by BS 7671.

6.1.2 See also Sections 12 and 13 of the Code of Practice.

6.1.3 Earth fault loop impedance and prospective fault current shall be verified for all operating modes. Tests representing the installation operating in charging mode shall be made with all inverters and bi-directional converters in the installation disconnected.

Note: the IET Code of Practice contains recommendations for determining prospective fault current and earth fault loop impedance in installations containing EESS.

Issue: 1.0	COPYRIGHT © The MCS Service Company Ltd 2021	MIS 3012
Date: 22/11/2021		Page 26 of 40

6.2 DOCUMENTATION & LABELLING

6.2.1 MCS Contractors shall collate a comprehensive document handover pack which, as a minimum, includes:

- Copies of all forms and checklists used to commission the system
- The maintenance requirements and maintenance services available
- Manufacturer user manuals and warranty details.
- the information given in Section 13 (but excluding Section 13.3) of the IET Code of Practice.

6.2.2 Documentation and labelling shall comply with BS EN IEC/IEEE 82079-1.

6.2.3 Appropriate labels should be used as detailed in Appendix C of the Code of Practice with the exception of those described in Figures C.2 and C.5 which shall be used in all circumstances. The label given in Figure C.3 shall be used for DC coupled and bespoke systems where the DC terminals are not concealed within the enclosure of a packaged AC system. Labels required by BS 7671 and any other relevant standards should also be provided.

6.3 HANDOVER

6.3.1 At the point at which the EESS is handed over to the client, the documentation as detailed in 6.2.1 shall be provided and explained along with a document signed by the MCS Contractor containing at least the following:

- A declaration, signed by the MCS Contractor's on-site representative, confirming that the installation meets the requirements of this standard
- Client name and address
- Site address (if different)
- MCS Contractor's name, address, contact details etc.
- List of the key components installed
- The estimation of system performance calculated according to Section 4
- Recommended interval for the first periodic inspection

Note: See Appendix D for a model handover document.

6.3.2 No later than 10 working days after commissioning, the installation shall be registered by the MCS Contractor on the MCS Installation Database (MID) and an MCS Certificate generated.

6.3.3 The MCS Certificate shall be sent to the customer with instruction to include it within the handover pack.

Issue: 1.0	COPYRIGHT © The MCS Service Company	MIS 3012
Date: 22/11/2021	Ltd 2021	Page 27 of 40

- 6.3.4 The generation of the certificate shall be undertaken in full compliance with the terms and conditions of use of the MID¹ and the registration of the system on the MID shall be undertaken only after the system has been fully installed and commissioned and not before.
- 6.3.5 A “per installation” fee is levied on MCS Contractors for each registration added to the database. Details of any such fee will be advised from time to time through MCS Certification Bodies.

7 MAINTENANCE

This section purposely left blank to be populated by the Working Group as best practice is defined.

8 ROLES & COMPETENCY

- 8.1.1 All personnel involved in the installation of an EESS, either employed by, or subcontracted to, the MCS Contractor shall be skilled or instructed for the activities they undertake (skilled “electrically” is defined in BS 7671).
- 8.1.2 Complete records of training and / or qualifications demonstrating the required competencies shall be maintained by the MCS Contractor, in particular:
 - Design personnel - Shall be able to demonstrate a thorough technical knowledge of the technologies involved and the interaction of associated technologies and be able to deliver a compliant design to the requirements of this Standard.
 - Installation personnel – Shall be able to demonstrate an adequate level of technical knowledge and installation skills, to install systems to the specified designed in accordance with the requirements of this Standard, applicable codes of practice, manufacturer’s instructions and Statutory Regulations.

Note: As a minimum MCS Contractors should have personnel with demonstrable training and / or experience of solar photovoltaic systems in accordance with the requirements of this Standard. Entry level qualifications as shown in Appendix A, may be deemed as suitable for simple non-complex systems.

9 REGIONAL OFFICES

Where the MCS Contractor wishes to design and commission under the Certification Scheme in regional offices, then these offices shall meet the requirements of this standard to be eligible for Certification.

¹ The terms and conditions of use can be found on the MCS Installation Database website.

Issue: 1.0	COPYRIGHT © The MCS Service Company Ltd 2021	MIS 3012
Date: 22/11/2021		Page 28 of 40

10 PUBLICATIONS, REFERENCE AND FURTHER READING

10.1.1 The below lists are provided so that MCS Contractors know which documents have been used as a basis for the development of the requirements of this standard and they are able to further research topics if they need to do so.

10.1.2 It is a requirement for MCS Contractors to own at least one copy of the following documents in each office or regional office undertaking design and commissioning work:

- BS 7671:2018+A1:2020 Requirements for Electrical Installations (IET Wiring Regulations Eighteenth Edition).
- IET Code of Practice for Electrical Energy Storage Systems (IET publication ISBN 978-1-83953-041-8 Paperback, 978-1-83953-389-1 Electronic)
- Engineering Recommendation G99 Issue 1 – Amendment 8 published 1 September 2021 - ‘Requirements for the connection of generation equipment in parallel with public distribution networks on or after 27 April 2019’
- Engineering Recommendation G98 Issue 1 – Amendment 8 published 1 September 2021 - ‘Requirements for the connection of Fully Type Tested Micro-generators (up to and including 16 A per phase) in parallel with public Low Voltage Distribution Networks on or after 27 April 2019’
- MCS 001 - MCS - Contractors certification scheme document.

10.1.3 It is not a requirement for MCS Contractors to own or have immediate access to the documents referenced unless this MIS standard does not adequately cover off the aspects required (for example, particular aspects for Class 4 systems that are not covered by product manufacturer’s certification).

- IET Code of Practice for Electric Vehicle Charging Equipment Installation (IET publication ISBN 978-1-78561-680-8 Paperback, 978-1-78561-681-5 Electronic)
- BS 5839-1:2017 Fire detection and fire alarm systems for buildings. Code of practice for design, installation, commissioning and maintenance of systems in non-domestic premises. Available from British Standards Institution (BSI)
- BS 5839-6:2019+A1:2020 Fire detection and fire alarm systems for buildings. Code of practice for the design, installation, commissioning and maintenance of fire detection and fire alarm systems in domestic premises.
- BS 7430:2011+A1:2015 Code of practice for protective earthing of electrical installations. Available from British Standards Institution (BSI)
- BS 7671:2018+A1:2020, Requirements for Electrical Installations (IET Wiring Regulations Eighteenth Edition).
- BS EN 50160:2010+A3:2019 Voltage characteristics of electricity supplied by public electricity networks. Available from British Standards Institution (BSI).

Issue: 1.0	COPYRIGHT © The MCS Service Company Ltd 2021	MIS 3012
Date: 22/11/2021		Page 29 of 40

- BS EN 60529:1992+A2:2013 Degrees of protection provided by enclosures (IP Code). Available from British Standards Institution (BSI).
- BS EN IEC 62485-1:2018 Safety requirements for secondary batteries and battery installations. General safety information.
- BS EN IEC 62485-2:2018 Safety requirements for secondary batteries and battery installations. Stationary batteries.
- BS EN IEC 62485-5 Safety requirements for secondary batteries and battery installations. Safe operation of stationary lithium ion batteries.
- ETSI TS 103 645 Cyber Security for Consumer Internet of Things.

Issue: 1.0	COPYRIGHT © The MCS Service Company Ltd 2021	MIS 3012
Date: 22/11/2021		Page 30 of 40

APPENDIX A – ENTRY LEVEL QUALIFICATIONS

The following courses and qualifications can help demonstrate competency but a single qualification should not be presumed to prove an individual competent for all situations.

Level 3 Award in the Design, Installation and Commissioning of Electrical Energy Storage Systems – LCL Awards (LCL Qualification Code – EESS, RQF Qualification Code 603/7131/6)

Issue: 1.0	COPYRIGHT © The MCS Service Company Ltd 2021	MIS 3012
Date: 22/11/2021		Page 31 of 40

APPENDIX B – PERFORMANCE ESTIMATION METHOD

Notes:

Performance estimates enable customers to compare different systems. The use of this MCS standard for performance estimates brings a comparable and consistent methodology for different solar PV and EESS configurations – particularly for self-consumption.

The estimates are based on the best knowledge of MCS of the EESS applications, domestic electricity consumption and solar PV generation.

The estimate of solar PV self-consumption with and without an EESS is detailed in MGD 003: Determining the Electrical Self-Consumption of Domestic Solar Photovoltaic (PV) Installations with and without Electrical Energy Storage.

Within this appendix the following definitions apply:

Electric Vehicle includes all classes of vehicle whereby some or all automotive traction is provided from an electrical storage device which can be charged or discharged from the electricity grid - including full electric vehicles (BEV) and plug-in hybrid vehicles (PHEV)

Electric Space Heating is any technology which is used under normal circumstances to provide the primary space heating to a building. This includes heat pumps and storage heaters but excludes single room heating devices such as fires or bar heaters

Electric Water Heating is any technology used for Domestic Hot Water for using an immersion element or heat pump.

Diverters are technologies which automatically apply a load when a domestic solar PV system is generating more electricity than the domestic consumption (before or after EESS charging). Examples include diverters for electric water heating or electric vehicle charging.

B 1 Determine the specific method for estimating system performance (See Figure B.1):

- B 1.1 Where the EESS is intended to increase the self-consumption of solar PV follow the procedure in section B 2.
- B 1.2 Where the EESS is **not** intended to increase the self-consumption of solar PV follow the procedure in section B 3
- B 1.3 Where the EESS is intended to increase the self-consumption of solar PV **and** additional services follow the procedure in section B 4.

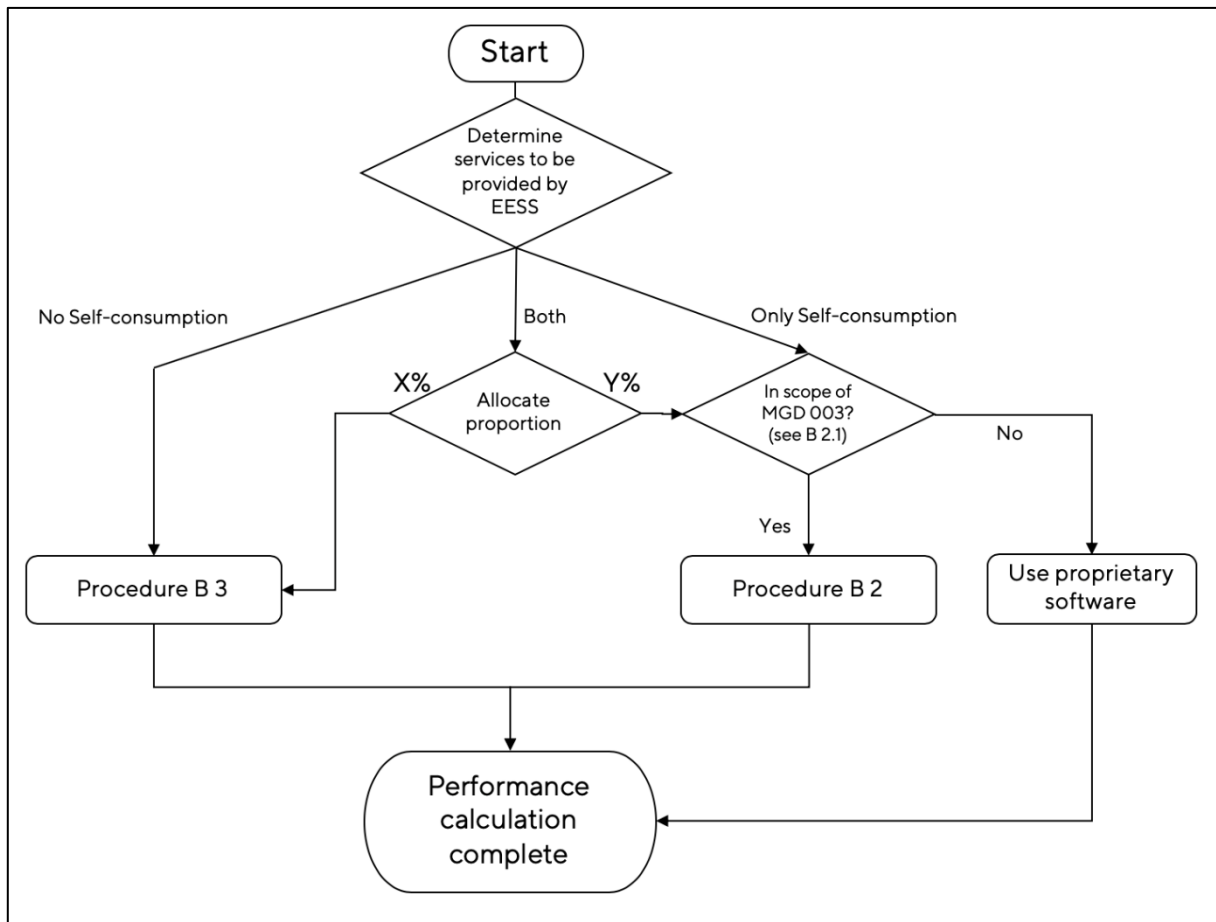

Figure B.1: Determine the required method to be used for MCS performance estimates

B 2 Where the EESS is intended to increase the self-consumption of solar PV

B 2.1 Determine if the application is within the scope of MGD 003:

- a) The EESS is serving a domestic building
- b) The annual electricity consumption is between 1500 kWh and 6000 kWh (excluding consumption attributable to electric vehicles and electrified space heating).
- c) The estimated annual generation of the solar PV system (calculated in accordance with MIS 3002) is between 1500kWh and 6000kWh
- d) There are no other forms of local electricity generation serving the building (other than the solar PV)

B 2.2 If the application is in-scope of MGD 003 then:

B 2.2.1 follow the procedure in MGD 003

B 2.2.2 complete sections C and D in the table prescribed in section 4.1.3. with the resulting parameters detailed in Section 7, Table 3 of MGD 003

B 2.2.3 append to the Important Note in 4.1.2 the estimate will be accompanied by the following text (in place of that given in section 7.5 of MGD 003)

Issue: 1.0	COPYRIGHT © The MCS Service Company	MIS 3012
Date: 22/11/2021	Ltd 2021	Page 33 of 40

“The solar PV self-consumption has been calculated in accordance with MCS document MGD 003. It does not account for the impact of power diverters, electric space heating, electric water heating or electric vehicle charging.”

B 2.3 If the application is out of scope of MGD 003 calculate self-consumption using proprietary software.

B 2.4 Where additional self-consumption is anticipated from power diverters, electric space heating, electric water heating or electric vehicle charging this can be calculated using any suitable method and the results shall be included in section E of the table prescribed in section 4.1.3 provided that the sum of all self-consumption shall not exceed 95% of:

- a) the total annual generation of the solar PV system
- b) the total annual domestic electricity consumption (including consumption attributed to domestic loads, EV charging and electric heating)

Note: even when solar PV generated electricity is used for EV charging etc. it is unlikely in most domestic situations for self-consumption to be 100% as there is always likely to be times, particularly mid-year, when some export is inevitable because the EV is not home or plugged in (or may be fully charged), space heating is not required and any power diverters have heated hot water cylinders to the maximum safe temperature.

B 3 Where the EESS is NOT intended to increase the self-consumption of solar PV

B 3.1 Calculate total energy discharged each year by multiplying the useable capacity by a factor of 730 and include in section E of the table prescribed in section 4.1.3.

Note: other services can include backup power, arbitrage, and ancillary services. Benefits are often a function of the number of units (kWh) charged and discharged which in turn is a function of the number of cycles. The greater the number of cycles then the greater the benefits can be but the longevity of the EESS can be adversely affected. Therefore, MCS limits the number of cycles assumed when calculating the total energy discharged each year to 2 cycles per day, 730 cycles each year.

B 4 Where the EESS is to increase the self-consumption of solar PV AND other services

B 4.1 Decide on the proportion of the EESS useable capacity in kWh:

- a) to be allocated for self-consumption and use that in the procedure prescribed in section B 2 (shown as Y% in Figure 1)
- b) to be allocated for other services and use that in the procedure prescribed in section B 3 (shown as X% in Figure 1)

Note: the sum total of the capacity allocated to each calculation cannot exceed 100% of the total useable capacity of the EESS. It is understood that the capacity allocated for each function can change throughout a year, but an assumed average should be used.

Issue: 1.0	COPYRIGHT © The MCS Service Company	MIS 3012
Date: 22/11/2021	Ltd 2021	Page 34 of 40

B 5 Worked example for an EESS with useable capacity of 13kWh

A. Solar PV Installation data		Calculations
Installed capacity of PV system – kWp (stc)	3 kWp	
Orientation of the PV system – degrees from South	45°	
Inclination of system – degrees from horizontal	30°	
Postcode region	1	
B. Performance calculations		
kWh/kWp (Kk) from table	925 kWh/kWp	
Shade Factor (SF)	1.0	
Estimated annual output (kWp x Kk x SF)	2775 kWh	$3 \times 925 \times 1.0$
C. Estimated PV self-consumption – PV Only		
Assumed occupancy archetype	Home half day	
Assumed annual domestic electricity consumption	3500 kWh	Table 9.14 from MGD003
Expected solar PV self-consumption (PV Only)	805 kWh	$2775 \times 29\%$
Grid electricity independence / Self-sufficiency (PV Only)	23%	$805/3500 \times 100$
D. Estimated PV self-consumption – with EESS		
Assumed usable capacity of electrical energy storage device, which is used for self-consumption	9 kWh	
Expected solar PV self-consumption (with EESS)	2276 kWh	$2775 \times 82\%$
Grid electricity independence / Self-sufficiency (with EESS)	65%	$2276/3500 \times 100$
E. Additional benefits from PV and EESS		
EESS capacity not used for self-consumption	4 kWh	$13 \text{ kWh} - 9 \text{ kWh}$
Total energy discharged per annum	2920 kWh	4×730
Additional self-consumption from EV, heat pumps, diverters (only when present)	360 kWh	$2775 \times 95\% - 2276$

APPENDIX C – COMMISSIONING CHECKLIST FOR DOMESTIC EESS

Commissioning Checklist	
Installation address	Reference:
	Date:
	Test Instruments:
PART 1: SYSTEM INSPECTION	
A System design/equipment selection and connection	Y / N / n/a
General check to confirm equipment complies with relevant standards.	[]
System installed in accordance with design.	[]
Equipment correctly selected and erected – according to standards and manufacturer's instructions.	[]
Equipment undamaged.	[]
Conductors correctly connected, identified and routed.	[]
Wiring systems and cables suitably supported in accordance with BS 7671	[]
Conductors suitably selected for voltage and current requirements.	[]
Switchgear and ancillary devices suitable for voltage and current requirements.	[]
Switchgear and ancillary devices correctly installed and connected.	[]
Components selected and erected to suit the location and any external influences.	[]
B Protection against electric shock	
i Basic protection (prevention of contact with live parts)	
Insulation of live parts (e.g. conductors) – correctly applied and suitable.	[]
Use of barriers or enclosures – suitable and with an appropriate IP rating.	[]
ii Additional protection (additional protection measures)	
Protection by the use of an RCD not exceeding 30 mA.	[]
Supplementary bonding.	[]
iii Other methods of protection	
SELV or PELV	[]
Double or reinforced insulation (Class II or equivalent equipment and circuits).	[]
iv Automatic disconnection of supply	
Suitable main earth provided.	[]
Earth connections suitably installed.	[]
Main protective bonding suitably installed.	[]
RCDs provided for fault protection.	[]
C General	
Equipment and circuits deployed to prevent mutual detrimental influence.	[]
Equipment located to allow suitable access arrangements.	[]
Labels and signs (including safety signs) displayed and durable.	[]

Systems that provide back-up or island mode power supply		
	Isolation of grid supply current-carrying conductors (Section 9.4 of IET CoP).	[]
	Provision of consumer's earth electrode (see Section 9.4.10 of IET CoP).	[]
	Additional protection by RCDs to supplement overcurrent protective devices to ensure adequate disconnection times are met (see Section 9.4.11 of IET CoP).	[]
	Provision of surge protection devices (see Section 9.7 of the IET CoP).	[]
	Staggered start/load-shedding on change-over (see Sections 9.8 and 9.9 of IET CoP).	[]
E	EESS location	
	Location/room has ventilation arrangements suitable for EESS and ancillary equipment.	[]
	Location selected suitable for IP rating of EESS components.	[]
	Fire prevention and detection measures implemented – as necessary for EESS technology.	[]
	Equipment located to minimise risk of mechanical damage (for example vehicle impact in a garage or near driveway).	[]
	Site safety signs displayed and durable – as necessary to meet EESS technology.	[]
F	EESS equipment	
	Equipment installed to manufacturer's requirements.	[]
	Clearance from adjacent objects meets manufacturer's specifications.	[]
	Ventilation of equipment meets manufacturer's requirements and remains unobstructed.	[]
	Clearance from any external heat sources acceptable – as relevant.	[]
	EESS equipment suitably accessible for maintenance and operation.	[]
	EESS labelling displayed and durable (e.g. 'dual supply' signs, other safety signs).	[]
Part 1: Notes and observations		

PART 2: TESTS ACCORDING TO BS 7671		
Tests carried out		[]
Part 2 BS 7671 certificate and schedule references		
Part 2: Notes and observations		
PART 3: EQUIPMENT AND SYSTEMS TESTS		
Data acquisition & control	Tests to ensure that the EESS data acquisition and control systems are performing correctly.	[]
Internet connectivity	Tests to ensure that the EESS is correctly configured and communicating.	[]
Displays/alarms	Checks to ensure correct function of any user displays or alarm mechanisms.	[]
Charge-discharge	Checks that EESS can correctly operate charge and discharge functions. Functional checks of batteries as recommended by the manufacturer or relevant standards (e.g. BS EN 61427-1 recommends battery capacity tests during commissioning).	[]
Thermal management	Checks to ensure correct function of any thermal management systems.	[]
Ventilation	Checks to ensure correct function of any ventilation systems and controls.	[]
Fire systems	Checks to ensure correct function of any fire detection or management systems.	[]
Wet chemical checks	Test to validate correct status of any liquids contained within the EESS (e.g. using hydrometer to check a lead-acid battery).	[]
Ancillary equipment	Checks to ensure correct function of any ancillary equipment forming part of the EESS (e.g. pumps, control valves etc.).	[]
Manufacturer's commissioning test report/schedule reference(s) (where appropriate)		
Part 3: Notes and observations		

PART 4: APPLICATION TESTS		
G98/G99	<p>Tests for EESS that can operate in parallel to the grid ('grid connected').</p> <p>At the most basic these tests may simply be a 'loss of mains test' to ensure that the system operates correctly when the mains supply is lost. For larger systems, a longer test sequence, such as G99 'injection testing', may be required.</p>	[]
Export limitation (G100)	<p>Where the EESS is part of a system that has been specified to control site export to a specific limit (export from on-site generation or the battery), a suite of tests will be required to prove the correction function of these systems.</p> <p>The commissioning tests expected by a DNO during the commissioning of an export limitation system are described in Engineering Recommendation G100.</p>	[]
Ancillary services	<p>Where a system is providing services to support the grid, specific commissioning tests will be required to prove that the system meets the requirements of that service.</p> <p>These tests typically involve simulating specific grid conditions and then monitoring the EESS to ensure it responds in the correct manner. An example of these tests would be where a test set is used to inject a specific grid frequency change - and then the EESS is monitored to ensure that it has a suitable charge/discharge ramp response.</p>	[]
Revenue metering/monitoring	<p>Where an EESS derives income from providing a service, metering and data acquisition systems are deployed to monitor the EESS and allow revenue to be collected. The correct operation and accuracy of these systems may need to be tested during commissioning.</p> <p>These tests may also be required for other meters in the system, such as those utilized to determine EESS usage as part of any warranty conditions.</p>	[]
Back-up – power quality	<p>Where an EESS provides a back-up or an island mode power supply, the quality of that supply may need to be verified during commissioning. These tests may vary from simple checks of voltage and frequency to a more detailed examination of wave-shape and harmonic content.</p>	[]
Backup – changeover	<p>Where an EESS provides a back-up power supply, the transition between on-grid and island mode operation may require functional testing.</p> <p>Information on the requirements for systems providing back-up functionality is provided in Sections 8.3 and 9.4. Commissioning tests need to determine the correct function of the measures adopted and may include:</p> <ul style="list-style-type: none"> • correct function of changeover switches/relays; • correct function of neutral-earth switching; • correct separation of essential and non-essential supplies; and • measurement of earth electrode resistance for the consumer's earth electrode. 	[]
Manufacturer's commissioning test report/schedule reference(s) (where appropriate)		
Part 4: Notes and observations		

APPENDIX D – MODEL HANDOVER DOCUMENT

EESS Handover Document		<input type="checkbox"/> Initial verification	
		<input type="checkbox"/> Periodic verification	
Client		Description of installation (key components installed)	
Installation Address			
Test Date			
		System Class	1 / 2 / 3 / 4
		Island Mode capable?	Yes / No
		Max Power Output	kW
		Useable Capacity	kWh
Contractor's name and address		Commissioning Certificate Part 1	
		Commissioning Certificate Part 2	
		Commissioning Certificate Part 3	
MCS Contact	Telephone: 0333 103 8130 Email: hello@mcscertified.com	Commissioning Certificate Part 4	
Design, Construction, Inspection and Testing			
<p>I/we being the person(s) responsible for the design, construction, inspection and testing of the Electrical Energy Storage System installation (as indicated by the signatures below), particulars of which are described above, having exercised reasonable skill and care when carrying out the design, construction, inspection and testing, hereby certify that the said work for which I/we have been responsible is, to the best of my/our knowledge and belief, in accordance with MCS Installation Standard MIS 3012.</p>			
Signature(s):		Next inspection recommended after not more than:	Years
Name(s):		Comments:	
Date: (The extent of liability of the signatory(s) is limited to the work described above)			